

TSC

Type Combined Steel Spring and Rubber Spring Unit Isolators
Size T20

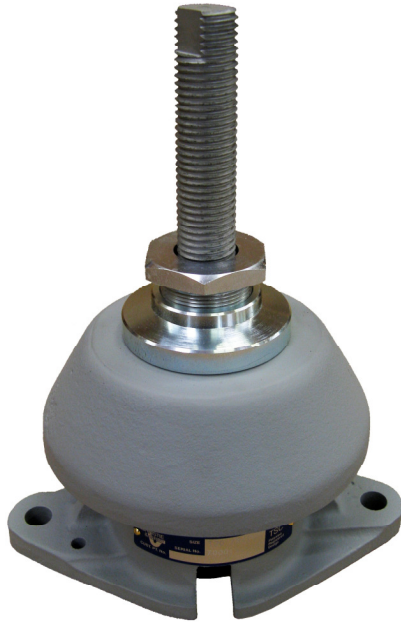

A major advance in design has successfully combined the best characteristics of steel springs and rubber springs to produce an efficient, compact and economical range of unit isolators suitable for many types of applications. Many variants of these isolators, designed and manufactured by us have now been in service for more than twenty years.

TSC unit isolators are highly effective in reducing the transmission of vibration, structure-borne noise and shock from a wide range of rotating and reciprocating machinery and in protecting sensitive apparatus from external disturbances. They are particularly suitable for marine and mobile applications as internal snubbers are incorporated to control movement of the isolated machine.

Type approval by Det Norske Veritas and American Bureau of Shipping.



Design Features

- Helical steel spring to BS1726 Class B.
- Inclined rubber springs are first grade natural rubber to metal bonded elements.
- SG iron castings to BS EN 1563 EN-GJS-400/15.
- Steel spring in most variants is isolated from the top casting by resilient seating pad reducing transmission of high frequency vibration and effectively damping spring coil surge resonance.
- Springs are pre-compressed on assembly, resulting in high equivalent static deflection and load capacity with minimum change between loaded and unloaded height.
- Rubber spring elements are effectively protected by the top casting and its extended skirt.
- Both types of spring support a proportion of the total load and thus the overall rate of creep is much reduced compared to an equivalent all-rubber unit isolator.
- A selection of steel and rubber springs, each having different vertical and lateral stiffness closely controlled in manufacture is available to facilitate the choice of the most appropriate isolator characteristics for a particular application.
- Optional soleplate is available to facilitate installation on resin chocks.
- Optional proof plates are available to enable removal of mountings for refurbishment (marine propulsion engines only).
- Optional height adjuster is available to facilitate installation.

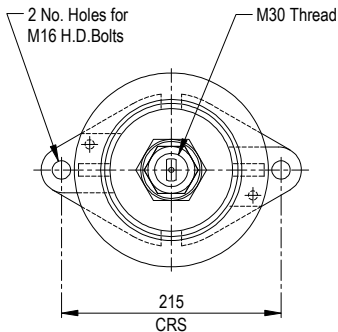
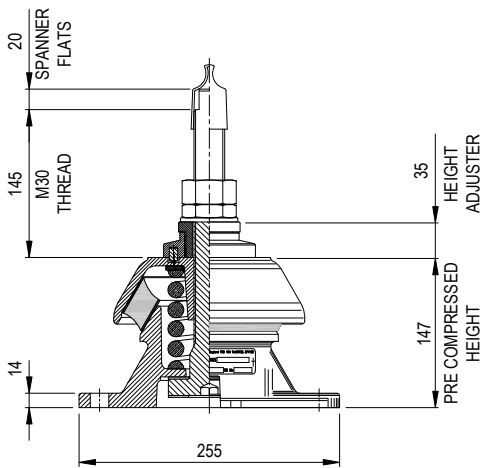
T20

TYPE TSC ISOLATOR SIZE T20

ISOLATOR REFERENCE	VERTICAL LOAD RANGE (kg)	DYNAMIC STIFFNESS (kN/m)		WEIGHT (kg) MAX
		VERTICAL	HORIZONTAL	
T20 45/100	400 - 700	752	813	9.0
T20 45/200	450 - 750	779	833	
T20 45/300	510 - 860	848	898	
T20 45/400	560 - 910	850	910	
T20 45/500	620 - 950	854	905	
T20 45/600	720 - 1050	973	1022	
T20 45/800	830 - 1200	987	1016	
T20 45/1000	1150 - 1550	1248	1273	
T20 55/100	660 - 1090	1276	1298	9.0
T20 55/200	710 - 1170	1324	1333	
T20 55/300	760 - 1250	1363	1355	
T20 55/400	815 - 1330	1399	1398	
T20 55/500	865 - 1410	1447	1436	
T20 55/600	920 - 1490	1482	1462	
T20 55/800	1020 - 1650	1566	1544	
T20 55/1000	1125 - 1810	1645	1608	
T20 65/200	960 - 1690	2421	2682	9.0
T20 65/300	1020 - 1790	2439	2676	
T20 65/400	1060 - 1810	2442	2693	
T20 65/500	1130 - 1910	2476	2727	
T20 65/600	1200 - 2000	2535	2738	
T20 65/800	1320 - 2150	2576	2781	
T20 65/1000	1600 - 2500	2712	2902	
T20 65/1500	2100 - 3000	2618	2743	
T20 75/800	1470 - 2300	5684	9068	9.0
T20 75/1000	1700 - 2700	6014	9584	
T20 75/1500	2100 - 3250	6035	9614	

Note! M30 Stud 145mm long as standard.

- All values of stiffness are nominal subject to $\pm 20\%$ variation on final assembly. The isolator rubber elements are pre-loaded 5 mm upon assembly.
- Stiffness is linear over working load range.
- Dynamic stiffness may vary with frequency. Values stated are reliable for calculation of low frequency characteristics below 100 Hz.

Application Notes:

- All connections to and from isolated machine must include flexible lengths, not only to prevent transmission of vibration through the connections and allow the system freedom of movement, but also to avoid possible failure of the connections.
- Analysis of the isolated system is normally undertaken by Christie & Grey to predict the response to ship motion, machine forces and shocks to enable the correct selection of flexible connections.

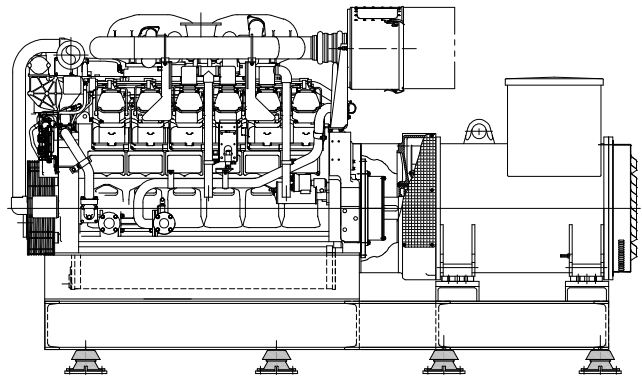
Typical Installation

TSC T20 isolators used on a generating set

For full instructions please refer to our data sheets DS040 and DS060.

For more detailed information and technical assistance please contact our Technical Department.

In the interests of continual development, the Company reserve the right to make modifications to these details without notice.



Christie & Grey Ltd
 Morley Road,
 Tonbridge, Kent
 TN9 1RA, England

T: +44 (0)1732 371100
 E: sales@christiegrey.com
 W: www.christiegrey.com



Christie & Grey
 SINCE 1914