

TSC

Type Combined Steel Spring and Rubber Spring Unit Isolators
Size T1 & T2



A major advance in design has successfully combined the best characteristics of steel springs and rubber springs to produce an efficient, compact and economical range of unit isolators suitable for many types of applications. Many variants of these isolators, designed and manufactured by us have now been in service for more than twenty years.

TSC unit isolators are highly effective in reducing the transmission of vibration, structure-borne noise and shock from a wide range of rotating and reciprocating machinery and in protecting sensitive apparatus from external disturbances. They are particularly suitable for marine and mobile applications as internal snubbers are incorporated to control movement of the isolated machine.

Type approval by Det Norske Veritas and American Bureau of Shipping.



Excellence in Anti Vibration Technology Since 1914
www.christiegrey.com

Design Features

- Helical steel spring to BS1726 Class B.
- Inclined rubber springs are first grade natural rubber to metal bonded elements.
- SG iron castings to BS EN 1563 EN-GJS-400/15.
- Steel spring in most variants is isolated from the top casting by resilient seating pad reducing transmission of high frequency vibration and effectively damping spring coil surge resonance.
- Springs are pre-compressed on assembly, resulting in high equivalent static deflection and load capacity with minimum change between loaded and unloaded height.
- Rubber spring elements are effectively protected by the top casting and its extended skirt.
- Both types of spring support a proportion of the total load and thus the overall rate of creep is much reduced compared to an equivalent all-rubber unit isolator.
- A selection of steel and rubber springs, each having different vertical and lateral stiffness closely controlled in manufacture is available to facilitate the choice of the most appropriate isolator characteristics for a particular application.
- Optional soleplate is available to facilitate installation on resin chocks.
- Design service life for standard marine applications 10 - 12 years.*

* Adhering to Christie & Grey installation, inspection, and maintenance instructions. For non-standard marine applications, please contact us for advice.

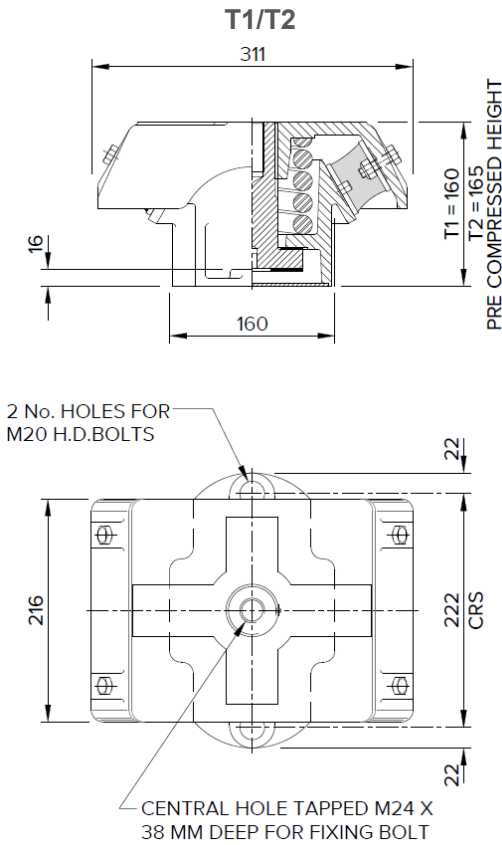

Christie & Grey
 SINCE 1914

TYPE TSC ISOLATORS SIZES T1 & T2

REFERENCE	VERTICAL LOAD RANGE (kg)	DYNAMIC STIFFNESS (kN/m)			WEIGHT MAX (kg)
		VERTICAL	HORIZONTAL		
			kz	kx	
T1 15/45	900 - 1300	1221	2912	583	29.3
T1 20/45	1200 - 1600	1310	3036	717	
T1 25/45	1500 - 1950	1373	3140	798	
T1 30/45	1900 - 2250	1519	3295	966	
T1 20/60	1400 - 2100	2560	5861	1050	
T1 25/60	1750 - 2350	2667	5934	1137	
T1 30/60	2000 - 2800	2772	6097	1300	
T1 40/60	2800 - 4000	3689	7589	2777	
T1 20/70	1600 - 2350	4250	10791	1714	
T1 25/70	1800 - 2800	4341	10873	1805	
T1 30/70	2200 - 3150	4446	11068	1958	
T1 40/70	2900 - 4100	5358	12570	3446	
T2 15/45	1180 - 1360	762	1141	546	28.8
T2 20/45	1290 - 1600	858	1265	678	
T2 20/55	1500 - 1800	1183	1817	787	
T2 20/60	1700 - 2170	1488	2591	983	
T2 25/60	2080 - 2500	1586	2688	1070	
T2 30/60	2370 - 2750	1694	2840	1232	
T2 30/70	2600 - 3150	2627	4697	1716	
T2 30/75	2800 - 3560	3955	7193	2310	
T2 40/60	2750 - 3900	2610	4336	2699	
T2 40/70	3200 - 4200	3538	6161	3186	
T2 50/45	2980 - 4370	3015	4751	3967	
T2 50/55	3250 - 4730	3315	5303	4071	
T2 50/60	3480 - 5020	3671	6207	4247	
T2 50/70	4000 - 5760	4683	7751	4539	

Please Note!

T1 & T2 Isolators leave our factory set at different Pre Compressed Heights.

T1 Pre Compressed Height = **160mm**

T2 Pre Compressed Height = **165mm**

- All values of stiffness are nominal subject to $\pm 15\%$ variation on final assembly. The isolator rubber elements are pre-loaded 6 mm upon assembly.
- Stiffness is linear over working load range.
- Dynamic stiffness may vary with frequency. Values stated are reliable for calculation of low frequency characteristics below 100 Hz.

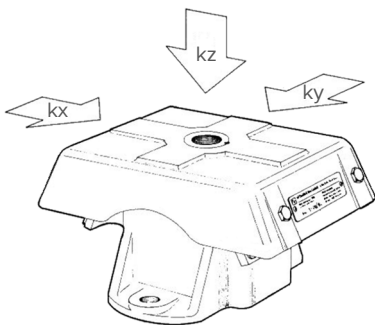
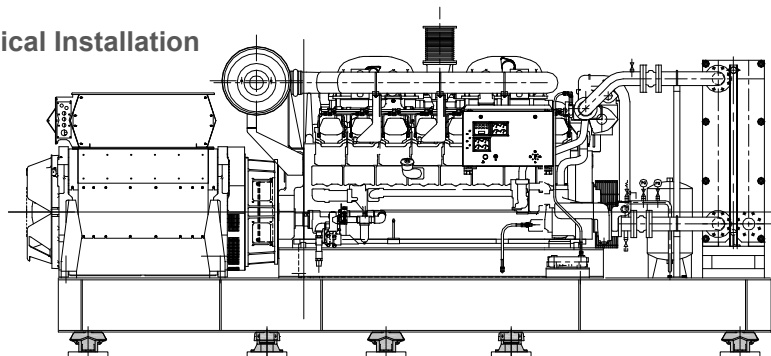
Typical Installation

Diesel driven alternator set on T2 isolators

Application Notes:

- Optimum system stiffness characteristics can be achieved by careful orientation of individual isolators.
- All connections to and from isolated machine must include flexible lengths, not only to prevent transmission of vibration through the connections and allow the system freedom of movement, but also to avoid possible failure of the connections.
- Analysis of the isolated system is normally undertaken by Christie & Grey to predict the response to ship motion, machine forces and shocks to enable the correct selection of flexible connections.

For full instructions please refer to our datasheets DS022 & DS040.

For more detailed information and technical assistance please contact our Technical Department.

In the interests of continual development, the Company reserve the right to make modifications to these details without notice.

Christie & Grey Ltd

Morley Road,
Tonbridge, Kent
TN9 1RA, England

T: +44 (0)1732 371100
E: sales@christiegrey.com
W: www.christiegrey.com



Christie & Grey
SINCE 1914