

TSC

Type Combined Steel Spring and Rubber Spring Unit Isolators
Size T15

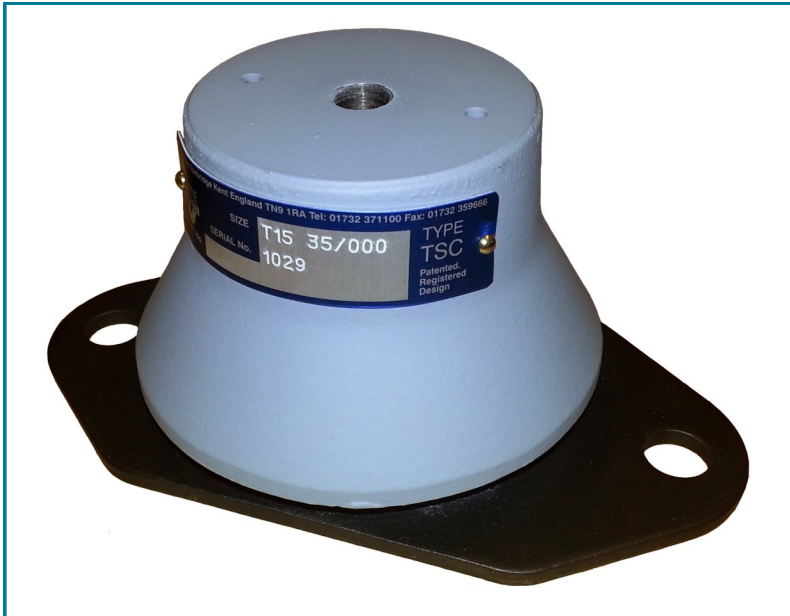

Design Features

- Helical steel spring to BS1726 Class B.
- Inclined rubber moulding manufactured from are first grade natural rubber.
- SG iron top casting to BS EN 1563 EN-GJS-400/15.
- High strength steel base housing.
- Steel spring is isolated from the base by integrated natural rubber reducing transmission of high frequency vibration and effectively damping spring coil surge resonance.
- Springs are pre-compressed on assembly, resulting in high equivalent static deflection and load capacity with minimum change between loaded and unloaded height.
- Rubber spring elements are effectively protected by the top casting and its extended skirt.
- Both types of spring support a proportion of the total load and thus the overall rate of creep is much reduced compared to an equivalent all-rubber unit isolator.
- A selection of steel and rubber springs, each having different vertical and lateral stiffness closely controlled in manufacture is available to facilitate the choice of the most appropriate isolator characteristics for a particular application.

For Marine and Light to Medium Industrial Applications

A major advance in design has successfully combined the best characteristics of steel springs and rubber springs to produce an efficient, compact and economical range of unit isolators suitable for many types of applications.

TSC unit isolators are highly effective in reducing the transmission of vibration, structure-borne noise and shock from a wide range of rotating and reciprocating machinery and in protecting sensitive apparatus from external disturbances. They are particularly suitable for marine and mobile applications as internal snubbers are incorporated to control movement of the isolated machine.

Testing of TSC T15 isolators has shown vertical isolation efficiencies in excess of ninety-four percent at primary operating speeds of fifteen hundred rpm and above.

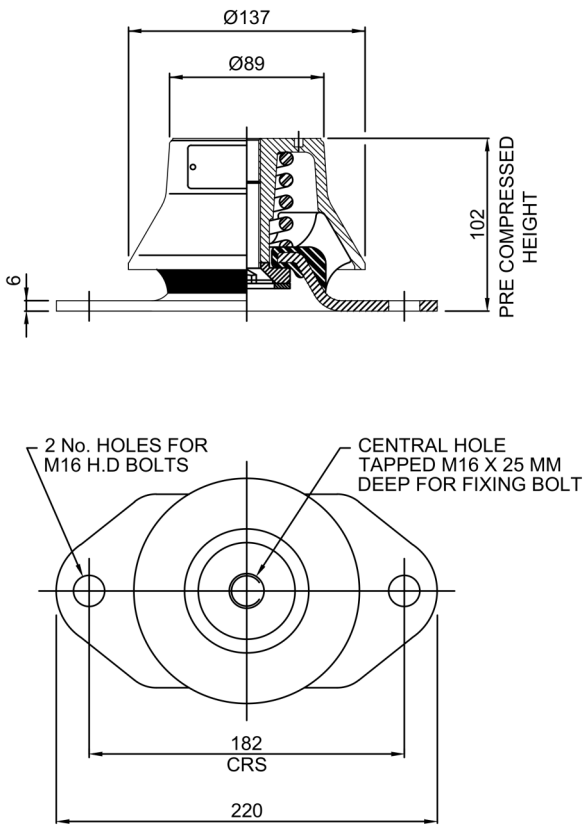

® Type approval by Det Norske Veritas and American Bureau of Shipping.

TSC T15

TYPE TSC ISOLATOR SIZE T15

REFERENCE	VERTICAL LOAD RANGE (kg)	DYNAMIC STIFFNESS (kN/m)		WT MAX (kg)
		VERTICAL	HORIZONTAL	
T15 35/000	110 - 225	333	456	3.3
T15 35/030	130 - 260	347	464	
T15 35/060	150 - 280	353	468	
T15 35/100	190 - 340	375	478	
T15 35/160	235 - 400	396	483	
T15 35/250	295 - 475	423	486	
T15 55/000	220 - 465	750	1131	3.3
T15 55/030	245 - 500	765	1140	
T15 55/060	260 - 520	763	1132	
T15 55/100	305 - 575	781	1136	
T15 55/160	350 - 640	808	1149	
T15 55/250	405 - 710	834	1150	
T15 65/000	495 - 1040	2015	2953	3.6
T15 65/030	520 - 1070	2033	2964	
T15 65/060	535 - 1095	2045	2977	
T15 65/100	580 - 1150	2061	2976	
T15 65/160	625 - 1210	2093	2998	
T15 65/250	680 - 1290	2119	2995	

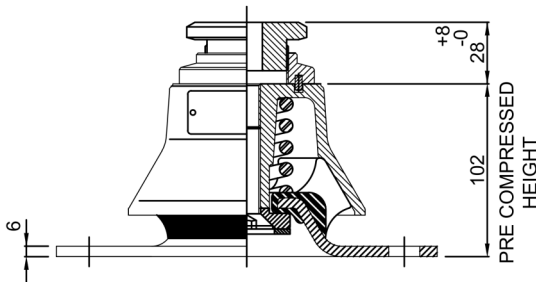
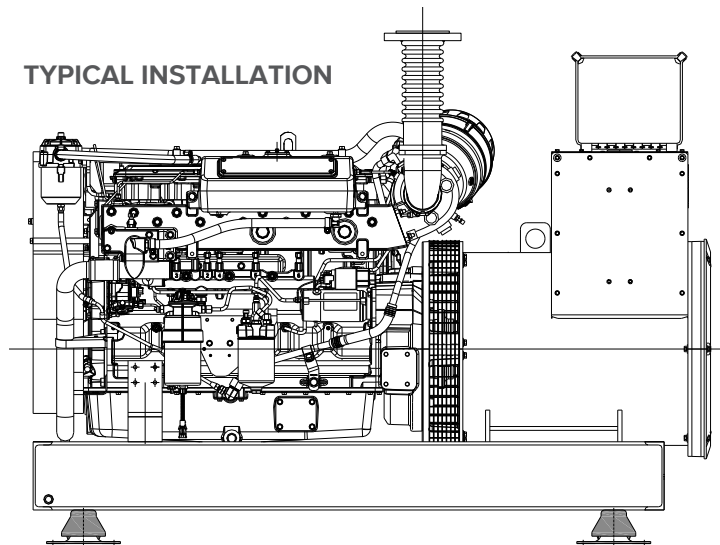
- The above values for load range and dynamic stiffness are provisional and may be subject to change.
- All values of stiffness are nominal subject to $\pm 20\%$ variation on final assembly.
- The isolator rubber element and steel spring are pre-loaded upon assembly.
- Stiffness is linear over working load range.
- Dynamic stiffness may vary with frequency. Values stated are reliable for calculation of low frequency characteristics below 100 Hz.

OPTIONAL HEIGHT ADJUSTER

TYPICAL INSTALLATION

For more detailed information and technical assistance please contact our Technical Department.

In the interests of continual development, the Company reserve the right to make modifications to these details without notice.

Christie & Grey Ltd

Morley Road,
Tonbridge, Kent
TN9 1RA, England

T: +44 (0)1732 371100
E: sales@christiegrey.com
W: www.christiegrey.com



Christie & Grey
SINCE 1914