

Marinflex

Type MPM & MPBM

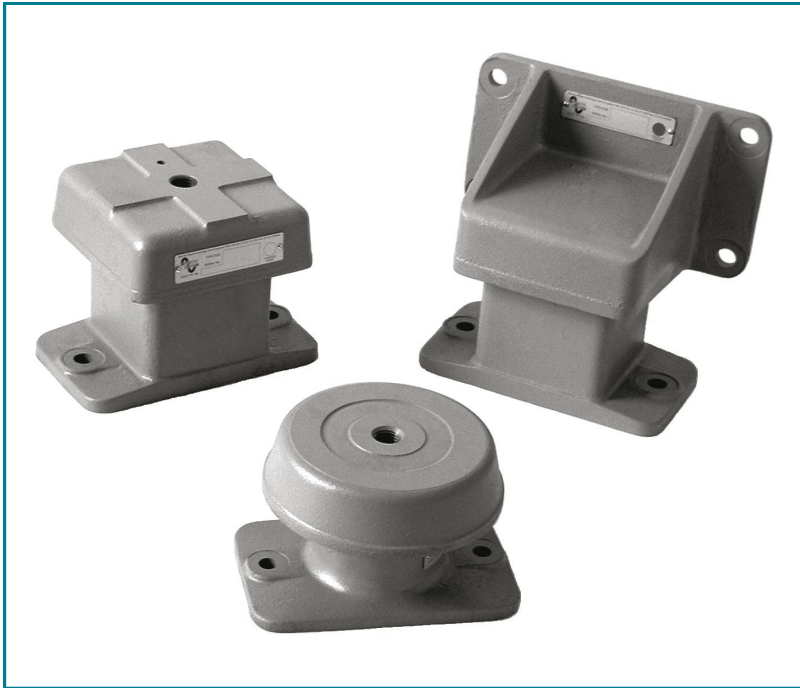

For many years these isolators have provided highly effective control of vibration, structure-borne noise and shock under most stringent and rigorous conditions experienced on marine and other mobile installations.

They have also been applied very successfully to a wide range of machinery employed in industrial and office buildings. Both of the two MPM sizes of isolator designed and manufactured by us are available in pedestal or bracket form for conventional or side mounting.

Different rubber stiffnesses are available for each isolator type and size and this facilitates selection of the isolators with the best characteristics for a particular application.



Excellence in Anti Vibration Technology Since 1914
www.christiegrey.com

Design Features

- SG iron castings to BS EN 1563 EN-GJS-400/15.
- Resilient elements are first grade natural rubber to metal bonded units.
- By loading the rubber elements in combined shear and compression a good balance between high load capacity and static deflection has been achieved.
- Rubber elements are contained and protected within top and base metals. The shape of the top and the rubber elements are designed to increase stiffness and control movement under overload conditions.
- Rebound washers are incorporated to control movement due to ship or vehicle motion.
- High lateral to vertical stiffness ratio of rubber element assists in the control of motion and in many instances obviates the need for additional external side and end restraints.

Typical Applications

- Marine Propulsion Engines.
- Diesel Generating Sets.
- Pumps and Compressors.
- Control Cabinets.



TYPE MPM & MPBM ISOLATORS

REFERENCE		DIMENSIONS (mm)														WT MAX (kg)
		A	B	C	D	E	F	G	H	J	K	L	M	N	P	
SIZE 1	MPM	127	140	178	82.5	19	63.5	16	-	-	12	-	-	-	-	9.0
	MPBM	193.5	178	89	82.5	19	63.5	16	268	128	12	89	114.5	19.5	12	12.5
SIZE 2	MPM	168.5	152	172	92	22	63.5	20	-	-	16	-	-	-	-	14.5
	MPBM	251	168	82.5	92	22	63.5	20	266	152.5	16	114.5	114.5	19	10	20.5

MPM SIZE 1

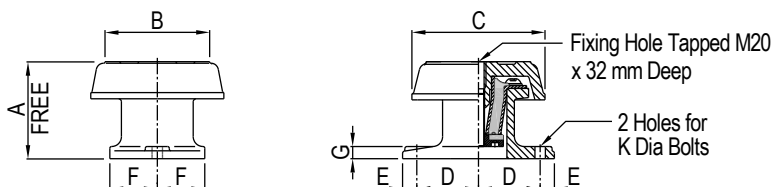

MPBM SIZE 1

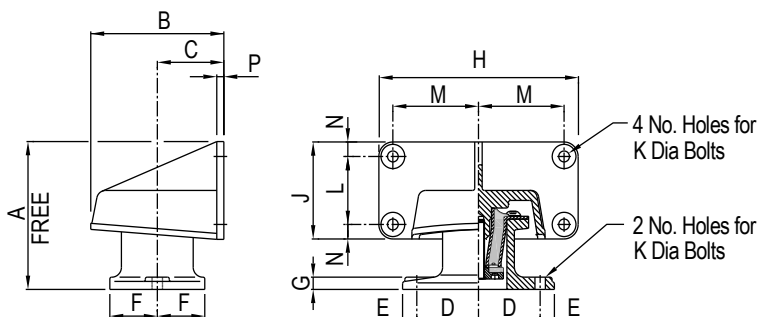

MPM SIZE 2

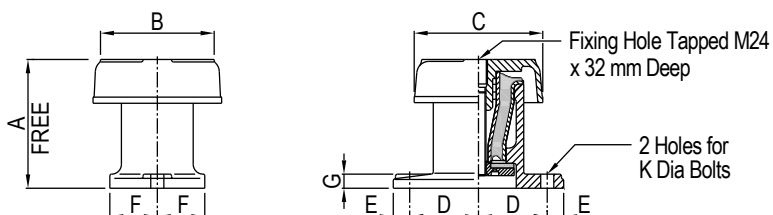

MPBM SIZE 2

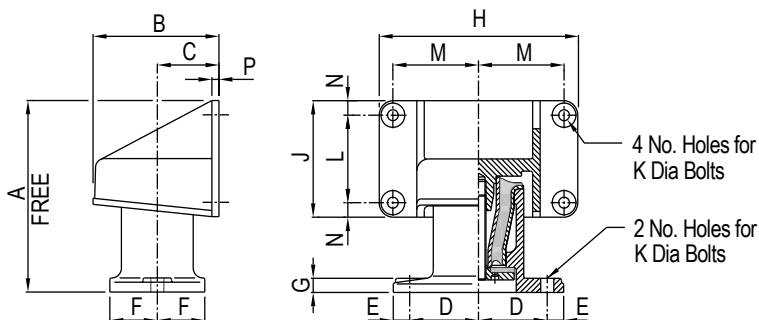

REFERENCE	LABEL COLOUR	MAXIMUM LOAD (kg)	VERTICAL DYNAMIC STIFFNESS (kN/m)	HORIZONTAL DYNAMIC STIFFNESS (kN/m)
MP(B)M SIZE 1	YELLOW	350	594	2376
	BLUE	562	975	3680
	GREEN	660	1212	4848
	RED	725	1562	6250
	BLACK	1000	2303	8748
MP(B)M SIZE 2	YELLOW	635	1067	4477
	BLUE	900	1587	6670
	GREEN	1060	2160	9072
	RED	1440	2750	11562
	BLACK	1590	3820	16065

Important Notes

- All variants available to special order on extended delivery.
- Stiffness is linear over the working load range.
- Dynamic Stiffness may vary with frequency. Values stated are reliable for calculation of low frequency characteristics below 100 Hz.

For full instructions please refer to our datasheets DS010

For more detailed information and technical assistance please contact our Technical Department.

In the interests of continual development, the Company reserve the right to make modifications to these details without notice.



Christie & Grey Ltd

Morley Road,
Tonbridge, Kent
TN9 1RA, England

T: +44 (0)1732 371100
E: sales@christiegrey.com
W: www.christiegrey.com



Christie & Grey
SINCE 1914