

Vibration and Shock Mountings

Type PD

Sizes P5D, P7D & P8 $\frac{1}{4}$ D



Typical Applications

- Diesel Generator Sets.
- Marine Propulsion Engines.
- Marine Chiller Units.



Type PD - One of a range of rubber shock and vibration mountings available from the Ministry of Defence Ship's Department BR.3021 Shock Manual.

The optional VSU (Vertical Stop Unit) and resilient end restraints shown below left are used to limit the shock displacements and the response to ship motion.

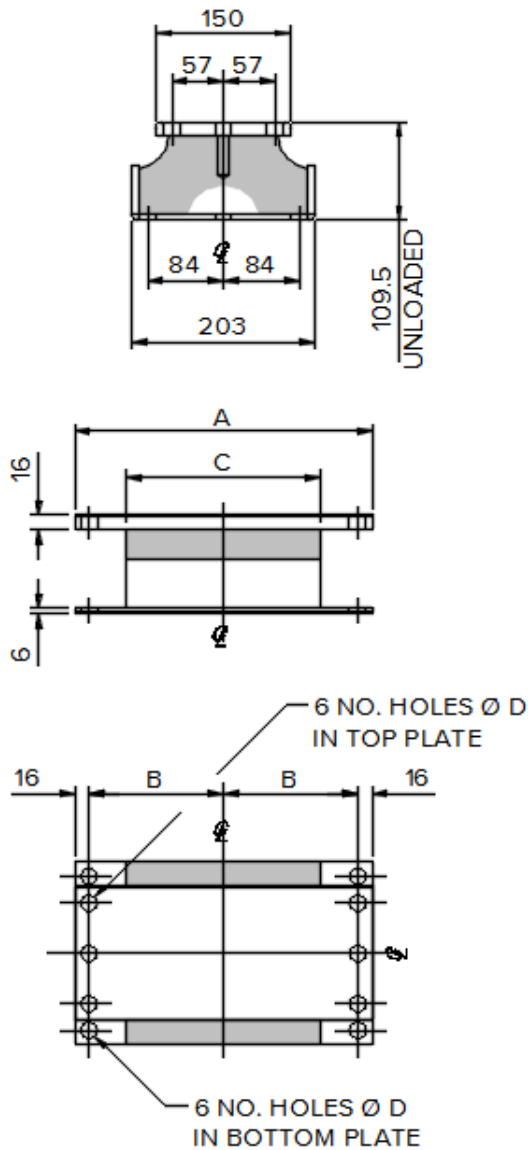

PD MOUNTS

PD MOUNTS SIZES P5D, P7D & P8¹/₄D

Type	P5D	P7D	P8 ¹ / ₄ D
Static Load Range (kg)	750-1100	1160-1700	1700-2500
Nominal Load (kg)	1000	1540	2270
Nominal Deflection (mm)	16	16	16
Vertical Static Stiffness (kN/m)	601	940	1380
Vertical Dynamic Stiffness (kN/m)	750	1192	1752
Dynamic/Static Ratio	1.25	1.27	1.27
Lateral Stiffness (kN/m)	554	906	1326
Lateral/Vertical Ratio	0.922	0.96	0.96
Longitudinal Stiffness	104	165	242
Longitudinal/Vertical Ratio	0.174	0.175	0.175
Shock Deflection (mm)	19	19	19

Type	Dimensions			
	A	B	C	D
P5D	210	89	127	14
P7D	267	117.5	184	14
P8 ¹ / ₄ D	330	149	216	18

Type	N.A.T.O Stock Numbers (Metric)
P5D	5340-99-537-5052
P7D	5340-99-537-5054
P8 ¹ / ₄ D	5340-99-769-7909

Design Features:

- A PD mount's athwartship stiffness is about 0.95 times the vertical stiffness in its normal orientation.
- The longitudinal stiffness is about 0.18 times the vertical stiffness.
- The rubber in a PD mount is protected by a flexible sealing paint.
- Metal parts are painted with low sheen black paint.
- PD mounts are the straight rubber developments of the circular type L mountings.
- The mounts will only achieve their full shock alleviation when they are functioning within their designed working ranges.

For more detailed information and technical assistance please contact our Technical Department.

In the interests of continual development, the Company reserve the right to make modifications to these details without notice.



Christie & Grey Ltd

Morley Road,
Tonbridge, Kent
TN9 1RA, England

T: +44 (0)1732 371100
E: sales@christiegrey.com
W: www.christiegrey.com

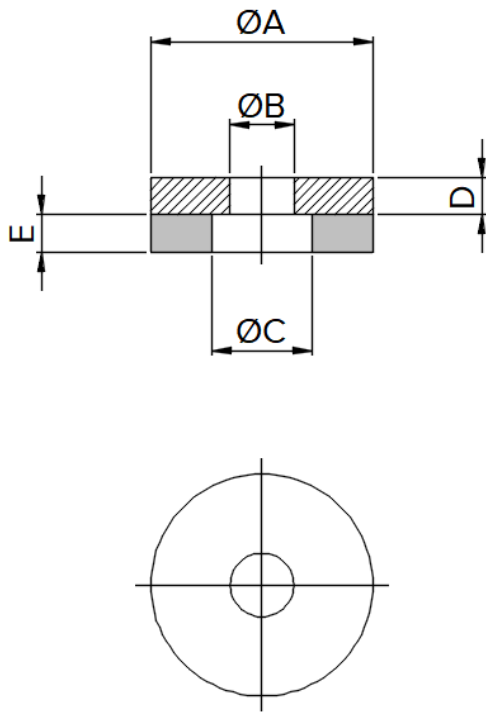

Christie & Grey
SINCE 1914

VERTICAL STOP UNIT WASHERS

VERTICAL STOP UNITS SIZES P5D, P7D & P8¹/₄D

Dimension	P5D	P7D	P8 ¹ / ₄ D	Special
A	86	98	111	150
B	26	32	38	43
C	48	51	54	67
D	16	20	24	10
E	25	25	25	25

Type	N.A.T.O Stock Numbers (Metric)
P5D	5340-99-537-5053
P7D	5340-99-537-5055
P8 ¹ / ₄ D	5340-99-537-5057

Design Features:

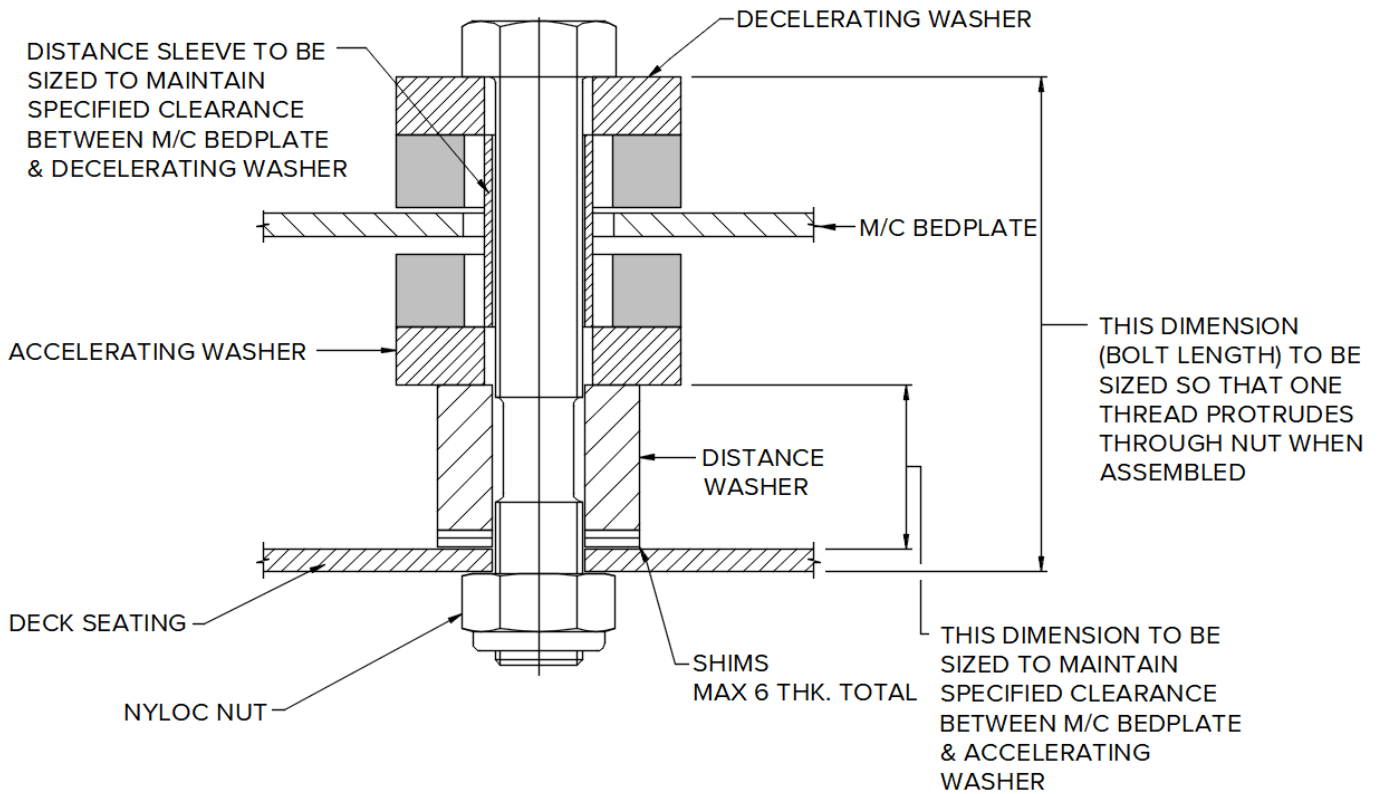
- The rubber in a VSU (Vertical Stop Unit) is protected by a flexible sealing paint.
- The clearances between accelerating washers, decelerating washers and machine bedplate will vary from application to application.

Typical detail of a Vertical Stop Unit

For more detailed information and technical assistance please contact our Technical Department.

In the interests of continual development, the Company reserve the right to make modifications to these details without notice.



Christie & Grey Ltd
 Morley Road,
 Tonbridge, Kent
 TN9 1RA, England

T: +44 (0)1732 371100
 E: sales@christiegrey.com
 W: www.christiegrey.com



Christie & Grey
 SINCE 1914

RESILIENT STOP

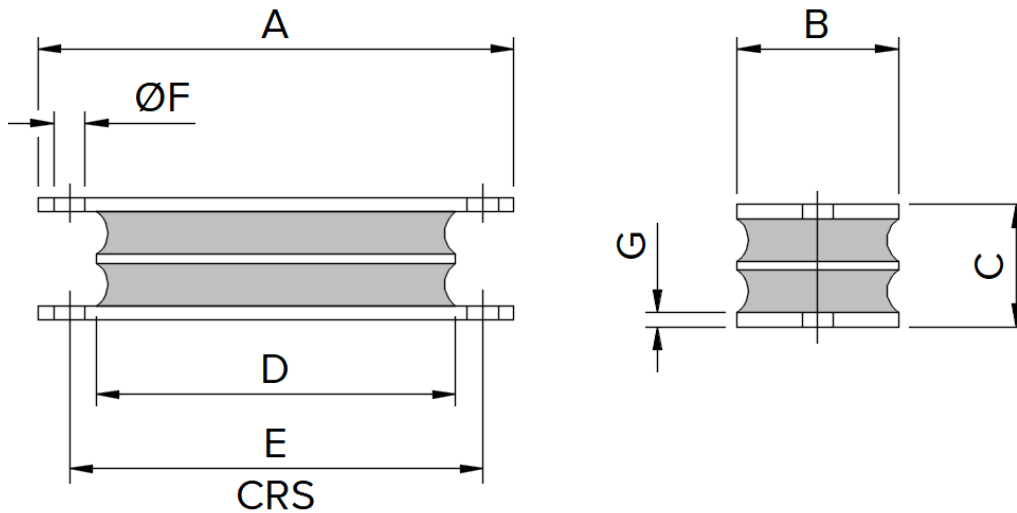

PART No.	RUBBER SHORE HARDNESS	MAX LOAD / DEFLECTION				DIMENSIONS							
		COMPRESSION		SHEAR		A	B	C	D	E	F	G	H
		kg	mm	kg	mm								
62.101	45	410	3.2	120	15.2	168	57	43	127	146	11	5	-
	55	575	2.8	117	9.4								
62.103	60	846	2.8	153	9.4	127	57	43	82	108	11	5	-
	70	989	2.3	159	7.4								
62.105	45	185	3.2	55	15.4	108	57	43	63	89	11	5	-
	70	490	2.6	90	8.2								

Design Features:

- The rubber in a Resilient Stop can be protected by a flexible sealing paint. The clearances between the RS unit and machine bedplate will vary from application to application.

Typical details of an application for Marine Shock Mounts

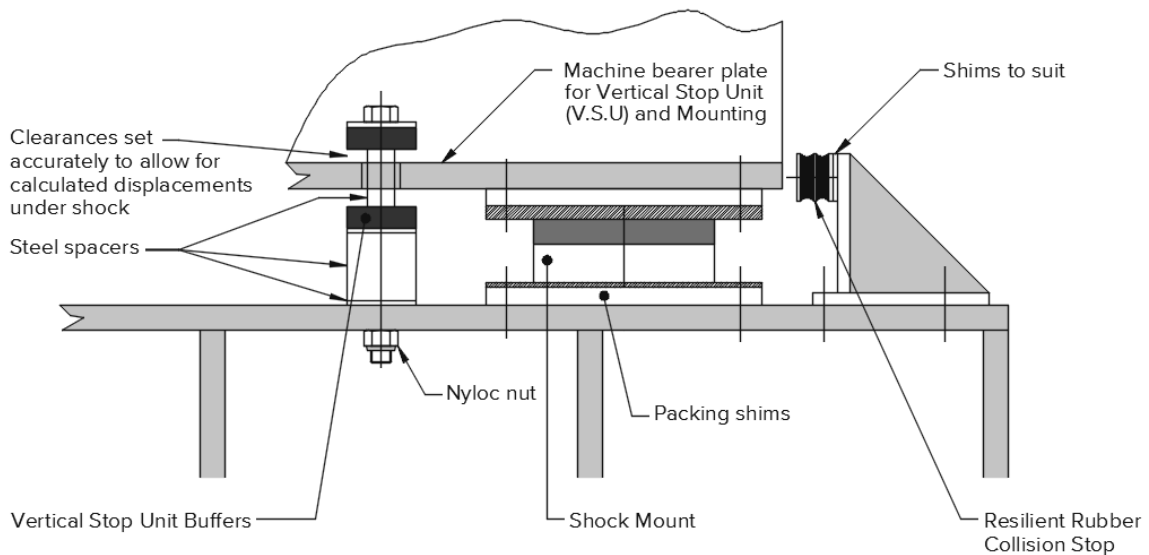

For more detailed information and technical assistance please contact our Technical Department.

In the interests of continual development, the Company reserve the right to make modifications to these details without notice.



Christie & Grey Ltd
 Morley Road,
 Tonbridge, Kent
 TN9 1RA, England

T: +44 (0)1732 371100
 E: sales@christiegrey.com
 W: www.christiegrey.com

