

Silicone Fluid Dampers

Type MD/3



Our range of Silicone Fluid Dampers type MD/3 are designed for use in conjunction with our Open Spring Mounting type OS, to provide both superior levels of isolation and also control transient motion.

Many applications will operate satisfactory with an un-damped helical steel spring, but where system resonances may be excited to unacceptable amplitudes due to the varying speeds of the machine or transient conditions, damping must be incorporated. The type MD/3 provides good control of motion at resonance whilst the forces generated at higher frequencies are small resulting in little increase in the perceived noise transmission.

DESIGN FEATURES

- Dampers are designed specifically for each application to provide between six and twelve percent damping.
- Silicone fluid properties remain stable over a wide temperature range.
- Fluid is chemically inert permitting a long life with no requirements to drain fluids and refill.
- Damping forces provided in all directions.
- Clearance within the damper permits motion of the machine without metal to metal contact.

TYPICAL APPLICATIONS

- Diesel Generating Sets.
- Centrifuges.
- Industrial Washing Machines.
- Test Rigs.
- Compressors.

MD/3 DAMPER

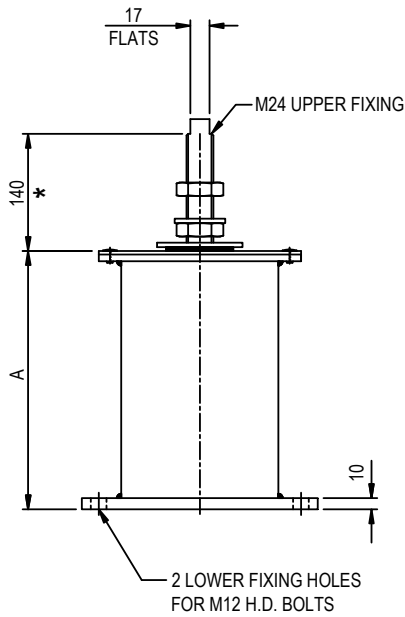

MD/3 DAMPER

MD/3 DAMPERS DESIGNED TO SUIT OPEN SPRING RANGES	HEIGHT 'A' (mm)	WEIGHT APPROX (kg)
OS25/1300 – OS25/2300 OS50/510 – OS50/1300 OS50/1400 – OS 50/1600 OS50/2000 – OS50/3200	173	17.3
OS75/800 – OS75/1600	193	21.3
OS75/2000 – OS75/3500 OS100/800 – OS100/1600	233	23

Please Note! Weights noted above are for guidance only. Each damper design is project specific and the component parts may vary and alter the final product weight.

* Nominal upper fixing stud 140mm long from top cover to end of thread, other lengths available to suit equipment frame at special request.

Each damper is designed as a special variant to suit the equipment being isolated. Damper internal components vary and are designed to work in tandem with the selected OS Open Springs.

Dampers are designed for use in conjunction with our OS Open Spring Isolators. Please refer to Leaflet PL024.

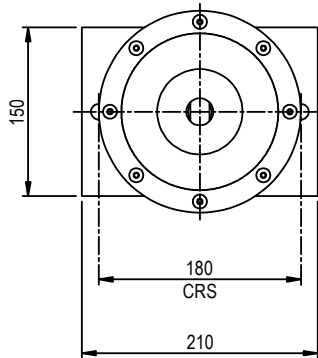

Typical Installation Diesel Genset on Dampers & Open Spring isolators

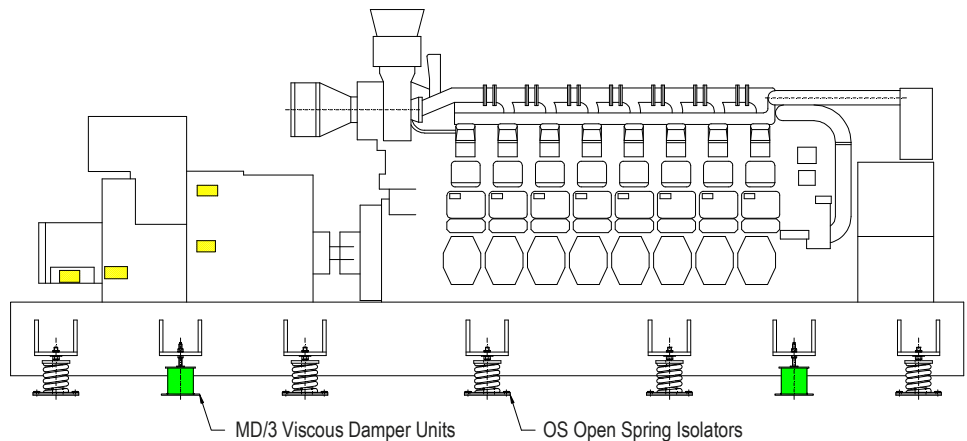

Full installation instructions are given on our data sheet DS033.

For more detailed information and technical assistance please contact our Technical Department.

In the interests of continual development, the Company reserves the right to make modifications to these details without notice.



Christie & Grey Limited

Morley Road, Tonbridge, Kent TN9 1RA, England

Telephone : +44 (0) 1732 371100 • Fax: +44 (0) 1732 359666

E-mail : sales@christiegrey.com • web site: www.christiegrey.com

